

PERFORMANCE STANDARD (continued)

RESILIENT TEST REQUIREMENTS OF A.S.T.M. C-923-00

TEST	RESULTS	ASTM METHOD
Chemical resistance 1 N Sulfuric acid 1 N Hydrochloric Acid	no weight loss no weight loss	at 22°C for 48h
Tensile strength	1200 psi or 8.5 MPa, min	D 412
Elongation at break	350% min	
Hardness	± 5 from mfg's. specified hardness	D 2240 (Shore A durometer)
Accelerated oven-aging	decr. of 15%, max. of original tensile strength, decr. of 20% max. of elongation	D 573, 70±1°C for 7 days
Compression set	decr. of 25%, max. of original deflection	D 395, Method B, at 70°C for 22h
Water absorption	increase of 10%, max. of original by weight	D 471, immerse 0.75 by 2-in. or 19 by 25-mm Specimen in distilled water at 70°C for 48h
Ozone resistance	rating 0	D 1171
Low-temp brittle point	no fracture at -40°C	D 746
Tear resistance	200 lbf/in. or 34 kN/m	D 624, Method B

Copyright ASTM INTERNATIONAL. Reprinted with permission

PART 6 • DIMENSIONAL DATA

A-LOK X-CEL Cross Sections / Pipe Size OD's

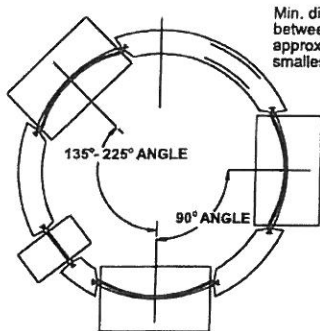
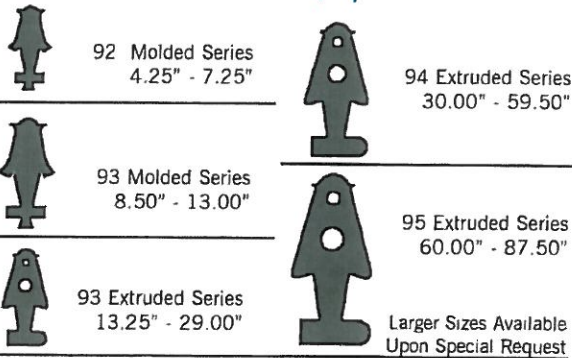

MAX. PIPE SIZE OD's

Min. distance between pipes is approx. 1/2 the smallest pipe OD

MAX. PIPE SIZE OD's

Manhole Diameter	135° - 225° Pipe Angle	90° Pipe Angle
42"	26.5"	22.0"
48"	31.5"	25.0"
60"	42.0"	32.0"
72"	52.5"	38.0"
84"	59.5"	44.0"
96"	73.5"	50.0"
108"	76.0"	56.0"
120"	85.0"	62.0"

PRODUCT SPECIFICATIONS

A flexible pipe to manhole connector shall be used whenever a pipe penetrates into a precast concrete manhole or structure. The connector shall be the A-LOK X-CEL CONNECTOR as manufactured by A-LOK PRODUCTS, INC., Tullytown, PA, or approved equal.

The design of the connector shall provide a flexible, watertight seal between the pipe and concrete structure. The connector shall assure that a seal is made between:

(1) The connector and the structure wall by casting the connector integrally with the structure wall during the manufacturing process in a manner that it will not pull out during pipe coupling. The connector shall also be capable of being cast into a round structure by curving the connector in a manner that allows it to remain centrally located within the structure wall and perpendicular to the pipe. This configuration will result in no loss of seal or deflection of pipe entering a concrete structure.

(2) The seal between the connector and the pipe shall be made by the compression of the connector between the outside circumference of the pipe and the interior hole opening of the structure. The connector shall be the only component to affect the seal between the pipe and structure.

The connector shall be made from materials that conform to the physical and chemical requirements outlined in Section 4, "Materials and Manufacture" of ASTM C-923 Standard Specification for Resilient Connectors between Reinforced Concrete Manhole Structures, Pipes, and Laterals, and the overall design will meet or exceed Section 7, "Test Methods and Requirements" of ASTM C-923.

The connector shall be sized specifically for the type of pipe being used and shall be installed in accordance with the recommendations of the manufacturer.

INSTALLATION INSTRUCTIONS

STEP 1:

Confirm that the pipe surface is smooth, clean and free of foreign materials, chips, gouges and form seams due to manufacturing or handling. Slightly bevel any sharp or blunt edges caused by the cutting of the pipe.

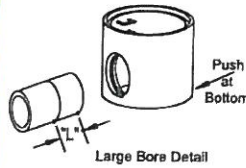

Large Bore Detail

STEP 2:

Lubricate the connector and the entire section of the pipe that will be inserted into the connector. The chart below lists A-LOK's minimum lubrication length "L".

PIPE SIZE	MIN. LUBRICATION LENGTH "L"
4" - 15"	12"
16" - 18"	18"
21" & Larger	24"

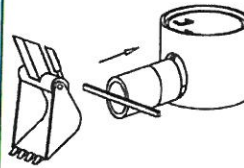

Small Bore Detail

STEP 3:

Center the pipe and connector square to each other and insert the pipe into the connector using a bar or back hoe depending on the size. Once the pipe is coupled with the connector, deflect the structure or pipe to achieve the proper angle.

WARNING

To ensure the A-LOK X-CEL Connector remains a flexible watertight connector, it is A-LOK Products, Inc. strong recommendation that no mortar be placed between the pipe and wall of the concrete structure. The use of mortar in this area would decrease the effectiveness of the connector to compensate for shear caused by settlement or ground movement.

NOTE:

To find approximate subgrade, measure from the outside base of the structure to the junction of the connector and flat spot. Then add the wall thickness of the pipe plus 1/4 inch.

CAUTION:

When installing pipe stubs for future pipeline installation, all stubs must be properly restrained to prevent any movement by means other than the A-LOK X-CEL Connector.

